

Free of maintenance stop valve with bellows seal - metallic sealing

ARI-FABA®-Plus ANSI
Class 150 / Class 300
Straight through with flanges
• TA - Luft TÜV-Test-No. 973-10183778

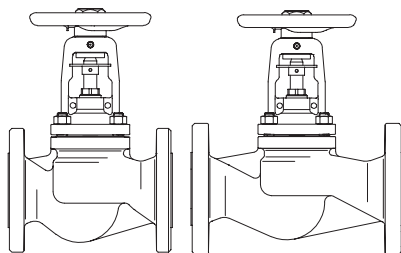

SA216WCB

Fig. 041

Page 2

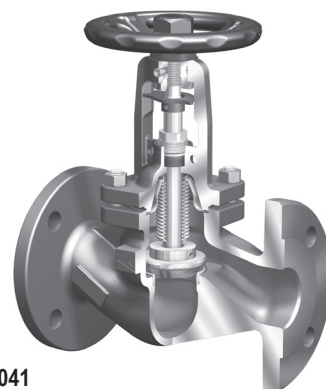
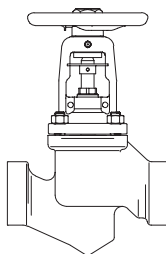

Fig. 041

ARI-FABA®-Plus ANSI
Class 300
Straight through with screwed sockets
Straight through with socket weld ends
• TA - Luft TÜV-Test-No. 973-10183778



SA105

Fig. 049

Page 3

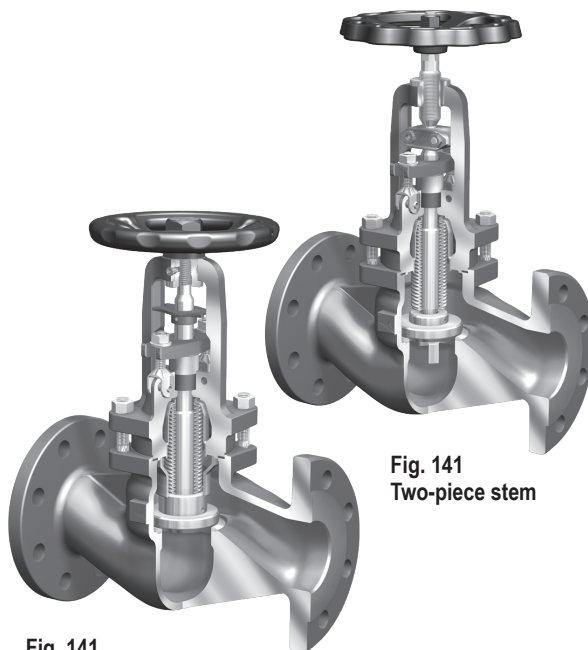
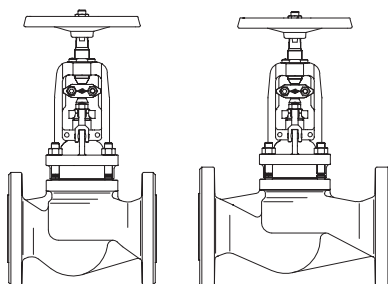

Fig. 141
Two-piece stem

Fig. 141
One-piece stem

ARI-FABA®-Supra I ANSI
ARI-FABA®-Supra C ANSI
Class 150 / Class 300
Straight through with flanges
• TA - Luft TÜV-Test-No. 973-10183778



SA216WCB

Fig. 141

Page 4

ARI-FABA®-Supra I ANSI
ARI-FABA®-Supra C ANSI
Class 300
Straight through with screwed sockets
Straight through with socket weld ends
• TA - Luft TÜV-Test-No. 973-10183778

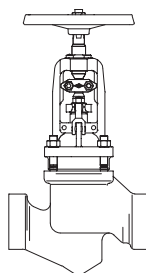

SA105

Fig. 149

Page 6

Features:

- Double wall bellows seal as standard
- Plug with marginal seat
- Stem with fine thread
- Flat lubricating nipple
- Locking device, countersunk
- Bonnet optimised for accessories
- Secondary sealing: gland packing
- Position indicator as standard
- Non-rotation lock for each nominal diameter

Additional features ARI-FABA®-Supra:

- Bellows seal welded to bonnet
- Bellows seal 10.000 load cycles
- Industrial version: Bellows seal shielded
Chemical version: Bellows seal flushed
- Stem back seal
- Yoke gasket, double chambered
- Welded seat
- Actuator retrofitting

Stop valve - straight through with flanges and bellows seal - Class 150 / 300 (SA216WCB)

Figure-No.	Nominal pressure	Material	Nominal diameter
32.041	ANSI150	SA216WCB	1/2" - 10"
35.041	ANSI300	SA216WCB	1/2" - 10"
Test: • TA - Luft TÜV-Test-No. 973-10183778			
Flanges acc. to ASME / ANSI B16.5			
At high differential pressures a balancing plug is necessary! (refer to page 8)			
Plug with marginal seat standard			

Selection of possible applications

Industry, Powerstations, Flue gas purification plant, processing technology, gas supply, vapour facilities, recycling facilities, vacuum facilities, hot water, heating technology, district heating, thermal oil applications, general plant manufacturing, etc. (other applications on request)

Selection of possible flow media

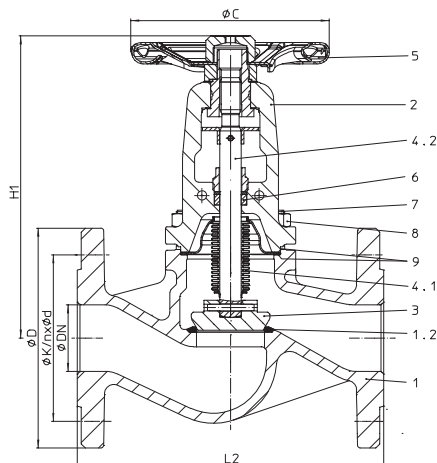
Steam, gases, hot water, thermal fluids, hot oil, process water, vacuum facilities, ammonia etc. (other flow media on request)

Parts

Pos.	Description	Fig. 32. / 35.041
1	Body	SA216WCB
1.2	Seat	E347-16
2	Bonnet	SA216WCB
3	Plug *	SA276Gr.420 (hardened)
4.1	Bellows seal	SA240Gr.316Ti
4.2	Stem	SA276Gr.420
5	Handwheel *	≤ 4" / DN100: A366 (cataphoretic coating) / ≥ 6" / DN150: SA278Class40 (epoxy-coating)
6	Packing ring	Pure graphite
7	Stud	SA193-B7
8	Hexagon nut	SA194-2H
9	Gasket *	Pure graphite (CrNi laminated with graphite)

* Spare part

Information / restriction of technical rules need to be observed!

Operating instructions can be ordered by phone +49 (0)5207 / 994-0 or fax +49 (0)5207 / 994-158 or -159.

A production allowance acc. to TRB 801 No. 45 exists

The engineer, designing a system or a plant, is responsible for the selection of the correct valve.

Dimensions

Nominal diameter	1/2"	3/4"	1"	1 1/2"	2"	2 1/2"	3"	4"	6"	8"	10"
L2 ANSI150 (inch)	4,25	4,62	5	6,5	8	8,5	9,5	11,5	16	19,5	24,5
L2 ANSI300 (inch)	6	7	8	9	10,5	11,5	12,5	14	17,5	22	24,5
H1 (inch)	8	8	8,3	8,9	9	9,7	10,5	14,4	16,8	21,7	28,4
ØC (inch)	4,9	4,9	4,9	5,9	5,9	6,9	8,9	11,8	15,8	20,5	20,5
Travel (inch)	0,25	0,25	0,3	0,5	0,5	0,65	0,8	1	1,6	2	2,75
Cv-value ANSI150 (us-gal)	5,6	7,7	13	31	48	82	117	179	442	714	1147
Cv-value ANSI300 (us-gal)	6,2	8,4	14	33,3	50,3	88	123	199	174	790	1275
Nominal diameter	15	20	25	40	50	65	80	100	150	200	250
L2 ANSI150 (mm)	108	117	127	165	203	216	241	292	406	495	622
L2 ANSI300 (mm)	152	178	203	229	267	292	318	356	444	559	622
H1 (mm)	205	205	210	225	230	245	265	365	425	550	720
ØC (mm)	125	125	125	150	150	175	225	300	400	520	520
Travel (mm)	6	6	8	13	13	16	20	25	40	50	70
Kvs-value ANSI150 (m³/h)	4,8	6,6	11,1	26,5	41	70	100	153	378	610	980
Zeta-value ANSI150 --	3,5	5,9	5,1	5,8	5,9	5,8	6,5	6,8	5,7	6,9	6,5
Kvs-value ANSI300 (m³/h)	5,3	7,2	12	28,5	43	75	105	170	405	675	1090
Zeta-value ANSI300 --	2,9	4,9	4,3	5	5,4	5,1	5,9	5,5	4,9	5,6	5,2

Standard-flange dimensions refer to page 12

Face-to-face dimension according to ANSI B16.10

Weights

Nominal diameter	1/2"	3/4"	1"	1 1/2"	2"	2 1/2"	3"	4"	6"	8"	10"
32.041 (lbs)	11,4	11,8	12,8	14,3	26,4	46,2	54	88	172	370	575
35.041 (lbs)	11,8	13,9	19	21	32,8	50,6	64	108	207	465	699
Nominal diameter	15	20	25	40	50	65	80	100	150	200	250
32.041 (kg)	5,2	5,4	5,8	6,5	12	21	24,5	40,2	78	168	261
35.041 (kg)	5,4	6,3	8,6	9,5	14,9	23	29	49,2	94	211	317

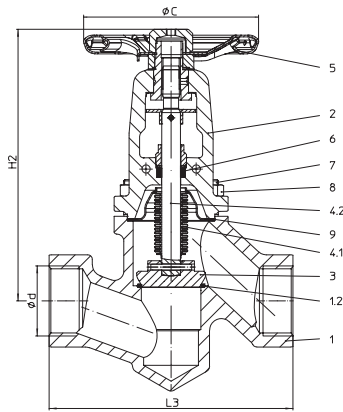
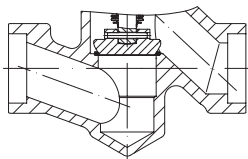
Stop valve - straight through with screwed sockets / Socket weld ends and bellows seal - Class 300 (SA105)

Fig. 049....2 with screwed sockets

Fig. 049....3 with socket weld ends

Parts

Pos.	Description	Fig. 45.049....2 / 45.049....3
1	Body	SA105
1.2	Seat	E347-16
2	Bonnet	SA216WCB
3	Plug *	SA276Gr.420 (hardened)
4.1	Bellows seal	SA240Gr.316Ti
4.2	Stem	SA276Gr.420
5	Handwheel *	A366 (cataphoretic coating)
6	Packing ring	Pure graphite
7	Stud	SA193-B7
8	Hexagon nut	SA194-2H
9	Gasket *	Pure graphite (CrNi laminated with graphite)

* Spare part

Information / restriction of technical rules need to be observed!

Operating instructions can be ordered by phone +49 (0)5207 / 994-0 or fax +49 (0)5207 / 994-158 or -159.

A production allowance acc. to TRB 801 No. 45 exists

The engineer, designing a system or a plant, is responsible for the selection of the correct valve.

Dimensions

Nominal diameter		1/2"	3/4"	1"	1 1/4"	1 1/2"	2"
L3	(inch)	4,6	4,6	5,5	7,3	7,3	8,2
H2	(inch)	8	8	8,5	9,1	9,1	9,45
ØC	(inch)	4,9	4,9	4,9	5,9	5,9	5,9
Travel	(inch)	0,25	0,25	0,3	0,5	0,5	0,5
Cv-value	(us-gal)	3,6	6,4	10	15	23,4	30,4
Nominal diameter		15	20	25	32	40	50
L3	(mm)	117	117	139	186	186	209
H2	(mm)	203	203	215	230	230	240
ØC	(mm)	125	125	125	150	150	150
Travel	(mm)	6	6	8	13	13	13
Kvs-value	(m³/h)	3,1	5,5	8,6	12,8	20	26
Zeta-value	--	8,4	8,4	8,4	10,2	10,2	14,8

Screwed socket dimensions and Socket weld ends dimensions refer to page 12

Face-to-face dimension according to ANSI B16.10

Weights

Nominal diameter		1/2"	3/4"	1"	1 1/4"	1 1/2"	2"
45.049....2 /3	(lbs)	6,4	6,4	8,2	13	13	16,1
Nominal diameter		15	20	25	32	40	50
45.049....2 /3	(kg)	2,9	2,9	3,7	5,9	5,9	7,3

Stop valve - straight through with flanges and bellows seal - Industrial version (SA216WCB)

Fig. 141....111 1 1/2" - 6" einteilige Spindel

Oberteil 8" - 10" einteilige Spindel

Fig. 141....112 1 1/2" - 6" zweiteilige Spindel

Oberteil 8" - 10" zweiteilige Spindel

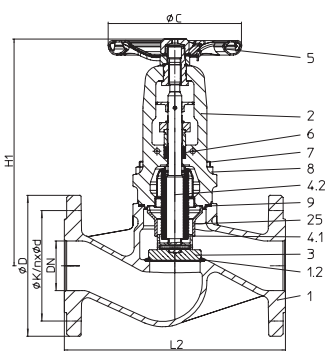
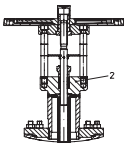
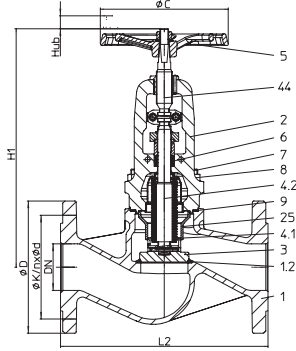
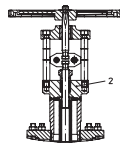
Figure-No.	Nominal pressure	Material	Nominal diameter
32.141....111	ANSI150	SA216WCB	1/2" - 10"
35.141....111	ANSI300	SA216WCB	1/2" - 10"
32.141....112	ANSI150	SA216WCB	1/2" - 10"
35.141....112	ANSI300	SA216WCB	1/2" - 10"
Test: • TA - Luft TÜV-Test-No. 973-10183778			
Flanges acc. to ASME / ANSI B16.5			
At high differential pressures a balancing plug is necessary! (refer to page 8)			
Plug with marginal seat standard			

Selection of possible applications

Industry, Powerstations, Flue gas purification plant, processing technology, gas supply, vapour facilities, recycling facilities, vacuum facilities, hot water, heating technology, district heating, thermal oil applications, general plant manufacturing, etc.
(other applications on request)

Selection of possible flow media

Steam, gases, hot water, thermal fluids, hot oil, process water, vacuum facilities, ammonia etc. (other flow media on request)

Parts

Pos.	Description	Fig. 32. / 35. 141....111 One-piece stem	Fig. 32. / 35. 141....112 Two-piece stem
1	Body	SA216WCB	
1.2	Seat	E347-16	
2	Bonnet	≤ 6" / DN150: SA216WCB / ≥ 8" / DN200: SA105, SA106Gr.B, SA516Gr.60	
3	Plug *	SA276Gr.420 (hardened)	
4.1	Bellows seal	SA240Gr.316Ti	
4.2	Stem	SA479Gr.316Ti	
5	Handwheel *	≤ 4" / DN100: A366 (cataphoretic coating) / ≥ 6" / DN150: SA395 (epoxy-coating)	SA395 (epoxy-coating)
6	Packing ring	Pure graphite	
7	Stud	SA193-B7	
8	Hexagon nut	SA194-2H	
9	Gasket *	Pure graphite (with With CrNi-grooved)	
25	Guide bush	≤ 1" / DN25: SA240Gr.316Ti / ≥ 1 1/2" / DN40: SA351CF8M	
44	Stem, top	--	AISI440

* Spare part

Information / restriction of technical rules need to be observed!

Operating instructions can be ordered by phone +49 (0)5207 / 994-0 or fax +49 (0)5207 / 994-158 or -159.

A production allowance acc. to TRB 801 No. 45 exists / The engineer, designing a system or a plant, is responsible for the selection of the correct valve.

Dimensions

NPS		1/2"	3/4"	1"	1 1/2"	2"	2 1/2"	3"	4"	6"	8"	10"
L2 ANSI150	(inch)	4,25	4,62	5	6,5	8	8,5	9,5	11,5	16	19,5	24,5
L2 ANSI300	(inch)	6	7	8	9	10,5	11,5	12,5	14	17,5	22	24,5
H1 One-piece stem	(inch)	8,9	8,9	9	10,7	10,8	11,8	14,9	18,1	22,5	30,9	37
H1 Two-piece stem	(inch)	9,5	9,5	9,5	11,5	11,6	13,2	15,6	19,9	23,8	31,9	37
ØC	(inch)	4,9	4,9	4,9	5,9	5,9	6,9	8,9	11,8	15,8	20,5	20,5
Travel	(inch)	0,25	0,25	0,3	0,5	0,5	0,65	0,8	1,0	1,6	2	2,75
Cv-value ANSI150	(us-gal)	4,9	7,1	11,7	30,4	47,4	81,9	117	179	442	920	1147
Cv-value ANSI300	(us-gal)	5,5	7,5	12,9	32,8	49,7	87,8	123	199	474	790	1275
DN		15	20	25	40	50	65	80	100	150	200	250
L2 ANSI150	(mm)	108	117	127	165	203	216	241	292	406	495	622
L2 ANSI300	(mm)	152	178	203	229	267	292	318	356	444	559	622
H1 One-piece stem	(mm)	225	225	230	270	275	300	380	460	570	785	940
H1 Two-piece stem	(mm)	240	240	240	290	295	335	395	505	605	810	940
ØC	(mm)	125	125	125	150	150	175	225	300	400	520	520
Travel	(mm)	6	6	8	13	13	16	20	25	40	50	70
Kvs-value ANSI150	(m³/h)	4,2	6,1	10	26	40,5	70	100	153	378	615	980
Zeta-value ANSI150	--	4,6	6,9	6,2	6	6,1	5,8	6,5	6,8	5,7	6,8	6,5
Kvs-value ANSI300	(m³/h)	4,7	6,4	11	28	42,5	75	105	170	405	675	1090
Zeta-value ANSI300	--	3,7	6,2	5,2	5,2	5,5	5,1	5,9	5,5	4,9	5,6	5,2

Standard-flange dimensions refer to page 12

Face-to-face dimension according to ANSI B16.10

Weights

NPS		1/2"	3/4"	1"	1 1/2"	2"	2 1/2"	3"	4"	6"	8"	10"
32.141	(lbs)	12,8	13,2	14,6	16,5	29,8	52,5	65,3	116	187	425	635
35.141	(lbs)	13,2	15,2	20,7	23,1	36,1	56,9	75,2	136	223	507	739
DN		15	20	25	40	50	65	80	100	150	200	250
32.141	(kg)	5,8	6	6,6	7,5	13,5	23,8	29,6	52,8	85	193	288
35.141	(kg)	6	6,9	9,4	10,5	16,4	25,8	34,1	61,8	101	230	335

Stop valve - straight through with flanges and bellows seal - Chemical version (SA216WCB)

Fig. 141....153 1 1/2" - 6
einteilige Spindel

Oberteil 8" - 10"
einteilige Spindel

Fig. 141....154 1 1/2" - 6
zweiteilige Spindel

Oberteil 8" - 10"
zweiteilige Spindel

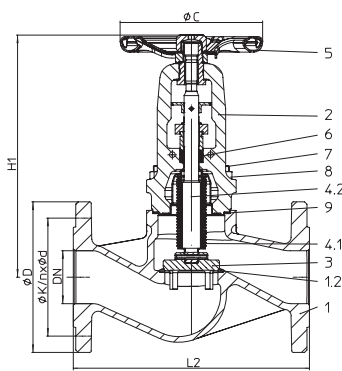
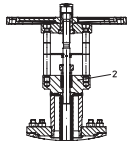
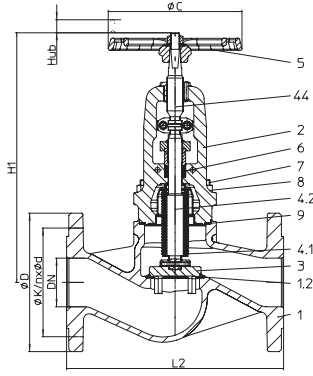
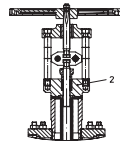
Figure-No.	Nominal pressure	Material	Nominal diameter
32.141....153	ANSI150	SA216WCB	1/2" - 10"
35.141....153	ANSI300	SA216WCB	1/2" - 10"
32.141....154	ANSI150	SA216WCB	1/2" - 10"
35.141....154	ANSI300	SA216WCB	1/2" - 10"
Test: • TA - Luft TÜV-Test-No. 973-10183778			
Flanges acc. to ASME / ANSI B16.5			
At high differential pressures a balancing plug is necessary! (refer to page 21)			
V-port plug with marginal seat standard			

Selection of possible applications

Industry, Powerstations, Flue gas purification plant, processing technology, gas supply, vapour facilities, recycling facilities, vacuum facilities, hot water, heating technology, district heating, thermal oil applications, general plant manufacturing, etc.
(other applications on request)

Selection of possible flow media

Steam, gases, hot water, thermal fluids, hot oil, process water, vacuum facilities, ammonia etc. (other flow media on request)

Parts

Pos.	Description	Fig. 32. / 35. 141....153 One-piece stem	Fig. 32. / 35. 141....154 Two-piece stem
1	Body	SA216WCB	
1.2	Seat	E347-16	
2	Bonnet	≤ 6" / DN150: SA216WCB / ≥ 8" / DN200: SA105, SA106Gr.B, SA516Gr.60	
3	Plug *	SA276Gr.420 (hardened)	
4.1	Bellows seal	SA240Gr.316Ti	
4.2	Stem	SA479Gr.316Ti	
5	Handwheel *	≤ 4" / DN100: A366 (cataphoretic coating) / ≥ 6" / DN150: SA395 (epoxy-coating)	SA395 (epoxy-coating)
6	Packing ring	Pure graphite	
7	Stud	SA193-B7	
8	Hexagon nut	SA194-2H	
9	Gasket *	Pure graphite (with With CrNi-grooved)	
44	Stem, top	--	AISI440

* Spare part

Information / restriction of technical rules need to be observed!

Operating instructions can be ordered by phone +49 (0)5207 / 994-0 or fax +49 (0)5207 / 994-158 or -159.

A production allowance acc. to TRB 801 No. 45 exists / The engineer, designing a system or a plant, is responsible for the selection of the correct valve.

Dimensions

NPS		1/2"	3/4"	1"	1 1/2"	2"	2 1/2"	3"	4"	6"	8"	10"
L2 ANSI150	(inch)	4,25	4,62	5	6,5	8	8,5	9,5	11,5	16	19,5	24,5
L2 ANSI300	(inch)	6	7	8	9	10,5	11,5	12,5	14	17,5	22	24,5
H1 One-piece stem	(inch)	8,9	8,9	9	10,7	10,8	11,8	14,9	18,1	22,5	30,9	37
H1 Two-piece stem	(inch)	9,5	9,5	9,5	11,5	11,6	13,2	15,6	19,9	23,8	31,9	37
ØC	(inch)	4,9	4,9	4,9	5,9	5,9	6,9	8,9	11,8	15,8	20,5	20,5
Travel	(inch)	0,25	0,25	0,3	0,5	0,5	0,65	0,8	1,0	1,6	2	2,75
Cv-value ANSI150	(us-gal)	4,7	6,4	10,8	28	43,3	70,2	100	143	357	613	931
Cv-value ANSI300	(us-gal)	5,1	7	11,7	29,8	45	74,9	105	158	380	679	1035
DN		15	20	25	40	50	65	80	100	150	200	250
L2 ANSI150	(mm)	108	117	127	165	203	216	241	292	406	495	622
L2 ANSI300	(mm)	152	178	203	229	267	292	318	356	444	559	622
H1 One-piece stem	(mm)	225	225	230	270	275	300	380	460	570	785	940
H1 Two-piece stem	(mm)	240	240	240	290	295	335	395	505	605	810	940
ØC	(mm)	125	125	125	150	150	175	225	300	400	520	520
Travel	(mm)	6	6	8	13	13	16	20	25	40	520	520
Kvs-value ANSI150	(m³/h)	4	5,5	9,2	24	37	60	86	122	305	524	796
Zeta-value ANSI150	--	5,1	8,4	7,4	7,1	7,3	7,9	8,8	10,7	8,7	9,3	9,8
Kvs-value ANSI300	(m³/h)	4,4	6	10	25,5	38,5	64	90	135	325	580	885
Zeta-value ANSI300	--	4,2	7,1	6,2	6,3	6,7	7	8,1	8,8	7,7	7,6	8

Standard-flange dimensions refer to page 12

Face-to-face dimension according to ANSI B16.10

Weights

NPS		1/2"	3/4"	1"	1 1/2"	2"	2 1/2"	3"	4"	6"	8"	10"
32.141	(lbs)	12,8	13,2	14,6	16,5	29,8	52,5	65,3	116	187	425	635
35.141	(lbs)	13,2	15,2	20,7	23,1	36,1	56,9	75,2	136	223	507	739
DN		15	20	25	40	50	65	80	100	150	200	250
32.141	(kg)	5,8	6	6,6	7,5	13,5	23,8	29,6	52,8	85	193	288
35.141	(kg)	6	6,9	9,4	10,5	16,4	25,8	34,1	61,8	101	230	335

Stop valve - straight through with screwed sockets / socket weld ends and bellows seal - Industrial version (SA105)

**Fig. 149....111....2 with screwed sockets
One-piece stem**

**Fig. 149....112....2 with screwed sockets
Two-piece stem**

Fig. 149....111....3 /112.... with socket weld ends

Figure-No.	Nominal pressure	Material	Nominal diameter
45.149....111....2	ANSI300	SA105	1/2" - 2"
45.149....112....2	ANSI300	SA105	1/2" - 2"
Screwed sockets acc. to DIN ISO 228 (BSP) or nach ASME / ANSI B1.20.1 (NPT)			
45.149....111....3	ANSI300	SA105	1/2" - 2"
45.149....112....3	ANSI300	SA105	1/2" - 2"
Socket ends according to ASME / ANSI B16.11			
Test: • TA - Luft TÜV-Test-No. 973-10183778			
Plug with marginal seat standard			

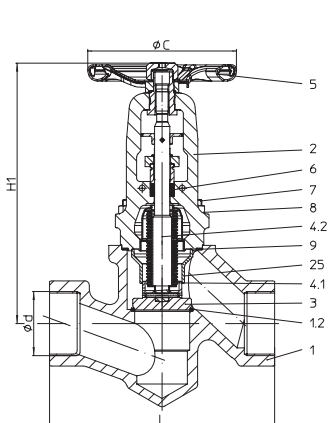
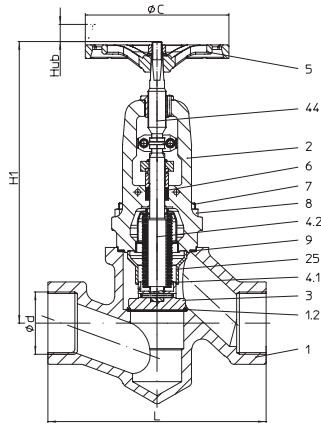
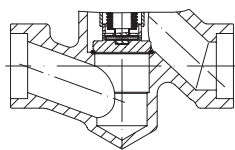
Selection of possible applications

Industry, Power plant, Flue gas purification plant, Processing technology, Gas supply, Vapour facilities, Recycling facilities, Vacuum plant, Thermal oil systems, General plant manufacturing, etc.

(other applications on request)

Selection of possible flow media

Steam, Gases, Hot water, Heat transfer oil, Ammonia, etc.

(other flow media on request)

Parts

Pos.	Description	Fig. 45.149....111 One-piece stem	Fig. 45.149....112 Two-piece stem
1	Body	SA105	
1.2	Seat	E347-16	
2	Bonnet	SA216WCB	
3	Plug *	SA276Gr.420 (hardened)	
4.1	Bellows seal	SA240Gr.316Ti	
4.2	Stem	SA479Gr.316Ti	
5	Handwheel *	A366 (cataphoretic coating)	SA395 (epoxy-coating)
6	Packing ring	Pure graphite	
7	Stud	SA193-B7	
8	Hexagon nut	SA194-2H	
9	Gasket *	Pure graphite (with With CrNi-grooved)	
25	Guide bush	≤ 1 1/4" / DN25: SA240Gr.316Ti / ≥ 1 1/2" / DN40: SA351CF8M	
44	Stem, top	--	AISI440

* Spare part

Information / restriction of technical rules need to be observed!

Operating instructions can be ordered by phone +49 (0)5207 / 994-0 or fax +49 (0)5207 / 994-158 or -159.

A production allowance acc. to TRB 801 No. 45 exists / The engineer, designing a system or a plant, is responsible for the selection of the correct valve.

Dimensions

NPS		1/2"	3/4"	1"	1 1/4"	1 1/2"	2"
L	(inch)	4,6	4,6	5,5	7,3	7,3	8,2
H1 One-piece stem	(inch)	8,9	8,9	9,3	9,3	10,8	11,2
H1 Two-piece stem	(inch)	9,5	9,5	10	10	11,6	12
ØC	(inch)	4,9	4,9	4,9	5,9	5,9	5,9
Travel	(inch)	0,25	0,25	0,3	0,5	0,5	0,5
Cv-value	(us-gal)	3,3	5,9	9,4	14,6	23,4	30,4
DN		15	20	25	32	40	50
L	(mm)	117	117	139	186	186	209
H1 One-piece stem	(mm)	225	225	235	235	275	285
H1 Two-piece stem	(mm)	240	240	255	255	295	305
ØC	(mm)	125	125	125	150	150	150
Travel	(mm)	6	6	8	13	13	13
Kvs-value	(m³/h)	2,8	5	8	12,5	20	26
Zeta-value	--	10,3	10,2	9,7	10,7	10,2	14,8

Screwed socket dimensions and Socket weld ends dimensions refer to page 12

Face-to-face dimension according to ANSI B16.10

Weights

NPS		1/2"	3/4"	1"	1 1/4"	1 1/2"	2"
45.149....2 /3	(lbs)	7,7	7,7	9,9	14,8	15,2	19,4
DN		15	20	25	32	40	50
45.149....2 /3	(kg)	3,5	3,5	4,5	6,7	6,9	8,8

Stop valve - straight through with screwed sockets / socket weld ends and bellows seal - Chemical version (SA105)

**Fig. 149....153....2 with screwed sockets
One-piece stem**
**Fig. 149....154....2 with screwed sockets
Two-piece stem**

Fig. 149....153....3 /154....3 with socket weld ends

Figure-No.	Nominal pressure	Material	Nominal diameter
45.149....153....2	ANSI300	SA105	1/2" - 2"
45.149....153....2	ANSI300	SA105	1/2" - 2"
Screwed sockets acc. to DIN ISO 228 (BSP) or nach ASME / ANSI B1.20.1 (NPT)			
45.149....154....3	ANSI300	SA105	1/2" - 2"
45.149....154....3	ANSI300	SA105	1/2" - 2"
Socket ends according to ASME / ANSI B16.11			
Test: • TA - Luft TÜV-Test-No. 973-10183778			
V-port plug with marginal seat standard			

Selection of possible applications

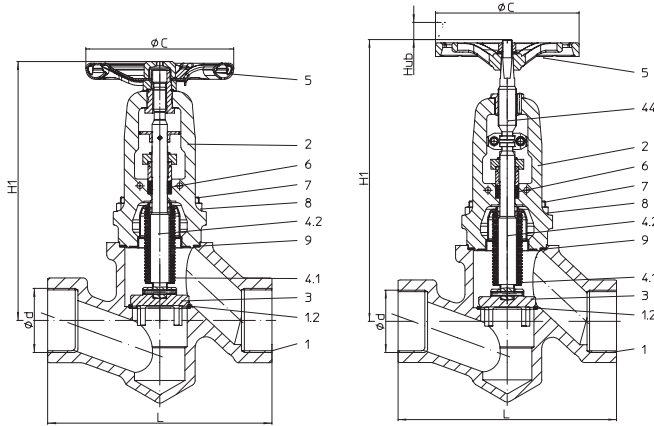
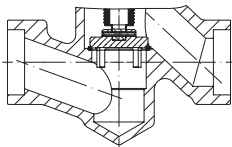
Industry, Power plant, Flue gas purification plant, Processing technology, Gas supply, Vapour facilities, Recycling facilities, Vacuum plant, Thermo-oil-systems, General plant manufacturing, etc.

(other applications on request)

Selection of possible flow media

Steam, Gases, Hot water, Heat transfer oil, Ammonia, etc.

(other flow media on request)

Parts

Pos.	Description	Fig. 45.149....153 One-piece stem	Fig. 45.149....154 Two-piece stem
1	Body	SA105	
1.2	Seat	E347-16	
2	Bonnet	SA216WCB	
3	Plug *	SA276Gr.420 (hardened)	
4.1	Bellows seal	SA240Gr.316Ti	
4.2	Stem	SA479Gr.316Ti	
5	Handwheel *	A366 (cataphoretic coating)	SA395 (epoxy-coating)
6	Packing ring	Pure graphite	
7	Stud	SA193-B7	
8	Hexagon nut	SA194-2H	
9	Gasket *	Pure graphite (with With CrNi-grooved)	
44	Stem, top	--	AISI440

* Spare part

Information / restriction of technical rules need to be observed!

Operating instructions can be ordered by phone +49 (0)5207 / 994-0 or fax +49 (0)5207 / 994-158 or -159.

A production allowance acc. to TRB 801 No. 45 exists / The engineer, designing a system or a plant, is responsible for the selection of the correct valve.

Dimensions

NPS		1/2"	3/4"	1"	1 1/4"	1 1/2"	2"
L	(inch)	4,6	4,6	5,5	7,3	7,3	8,2
H1 One-piece stem	(inch)	8,9	8,9	9,3	9,3	10,8	11,2
H1 Two-piece stem	(inch)	9,5	9,5	10	10	11,6	12
ØC	(inch)	4,9	4,9	4,9	5,9	5,9	5,9
Travel	(inch)	0,25	0,25	0,3	0,5	0,5	0,5
Cv-value	(us-gal)	3	5,5	8,5	12,9	21,3	27,5
DN		15	20	25	32	40	50
L	(mm)	117	117	139	186	186	209
H1 One-piece stem	(mm)	225	225	235	235	275	285
H1 Two-piece stem	(mm)	240	240	255	255	295	305
ØC	(mm)	125	125	125	150	150	150
Travel	(mm)	6	6	8	13	13	13
Kvs-value	(m³/h)	2,6	4,7	7,3	11	18,2	23,5
Zeta-value	--	12	11,6	11,7	13,8	12,3	18,1

Screwed socket dimensions and Socket weld ends dimensions refer to page 12

Face-to-face dimension according to ANSI B16.10

Weights

NPS		1/2"	3/4"	1"	1 1/4"	1 1/2"	2"
45.149....2 /3	(lbs)	7,7	7,7	9,9	14,8	15,2	19,4
DN		15	20	25	32	40	50
45.149....2 /3	(kg)	3,5	3,5	4,5	6,7	6,9	8,8

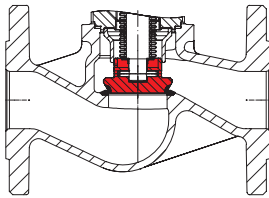

Isolation plug with marginal seat; stellite

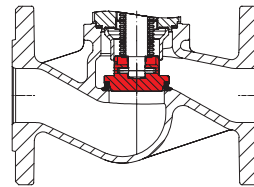

Plug with soft seal
Max. operating temperature 392°F / 200°C at PTFE + 25% Kohle

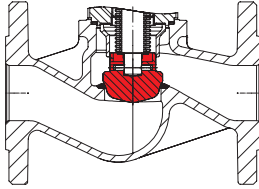

Regulating plug with marginal seat

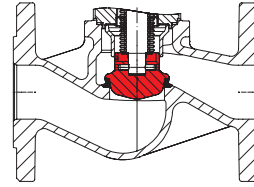

Regulating plug with soft seal
Max. operating temperature 392°F / 200°C at PTFE + 25% Kohle

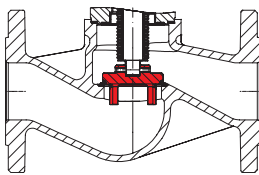

V-port plug with marginal seat; stellite

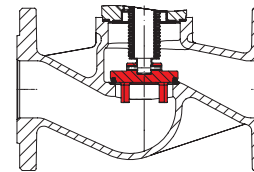

V-port plug with soft seal
Max. operating temperature 392°F / 200°C at PTFE + 25% Kohle

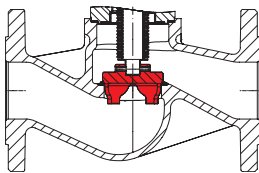

V-port regulating plug with marginal seat

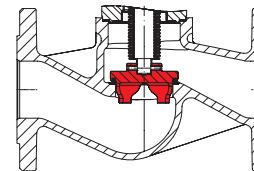

V-port regulating plug with soft seal
Max. operating temperature 392°F / 200°C at PTFE + 25% Kohle

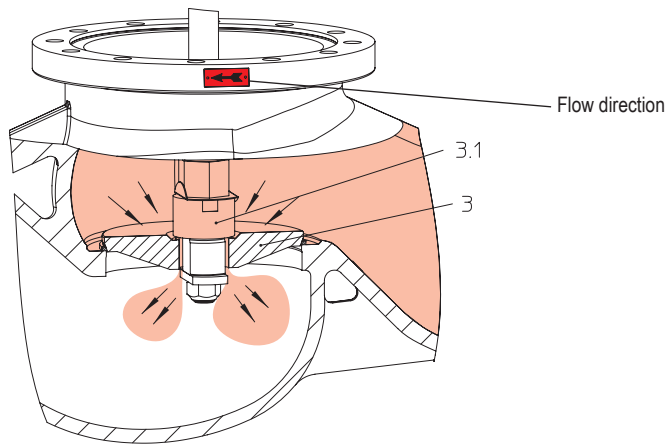

Valves with balancing plugs have to be installed with medium flowing over the plug (3) as indicated by flow direction arrow on valve body.

Working principles:

When the valve is closed, anticlockwise rotation of the hand wheel lifts the pilot plug (3.1) off the larger balancing plug (3).

This allows the medium to pass through the plug and equalizes the pressure of the medium under the plug (3). After the pressures have been equalized within the values stated in the table, the valve can be opened by turning the valve further with normal manual force.

Balancing plugs are fully effective only in closed systems.

The pressures of the medium on either side of the plug can not be equalized if the medium is discharged into open air.

A bypass line or some other arrangement is necessary if too much time is required for pressure equalization owing to the volume in the piping system.

ARI-stop valves with differential pressures exceeding the following pressures, have to be fitted with pressure balancing plugs

Nominal diameter		6"	8"	10"
max. differential pressure (ΔP)	(psi)	305	203	131
Nominal diameter		150	200	250
max. differential pressure (ΔP)	(bar)	21	14	9

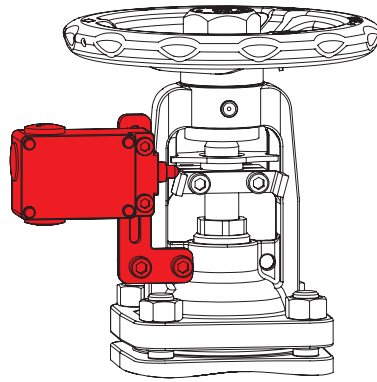

Limit switch

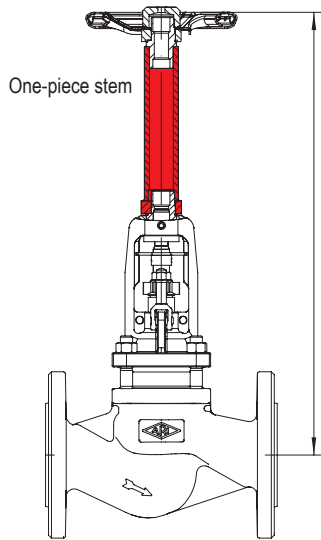

One-piece stem

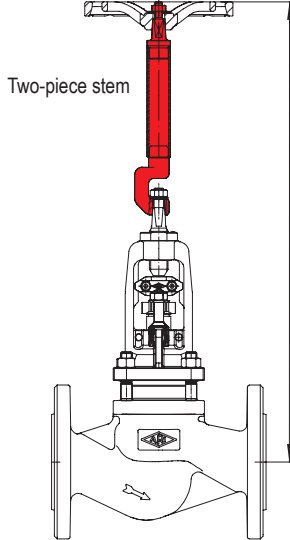

Two-piece stem

Stem extension (please specify height in your order)

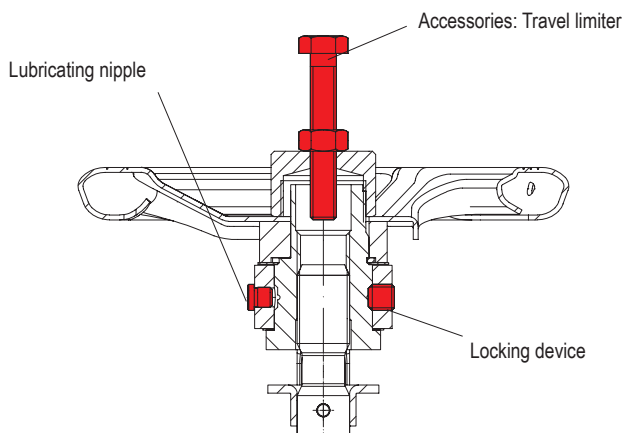

Lubricating nipple

Accessories: Travel limiter

Locking device

Travel limiter
 (Accessories are not included !)

NPS (inch)	DN (mm)	Hexagon screw (mm x mm)
1/2" - 3"	15-80	M8 x 55
4"	100	M12 x 70
6"	150	M12 x 80
8"	200	M12 x 100
10"	250	M12 x 120

Lubricating nipple / Locking device / Travel limiter
 (only construction FABA-Plus and FABA-Supra with one-piece stem)

Pneumatic actuator ARI-FA

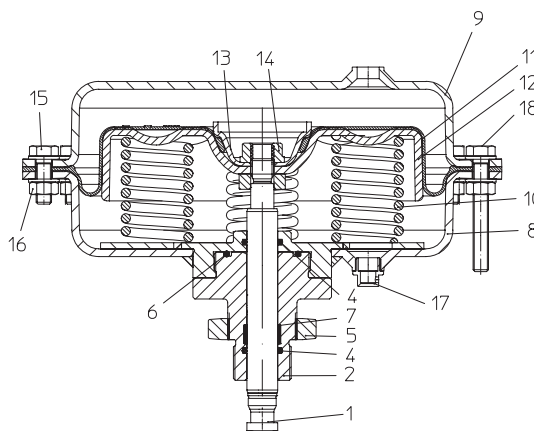
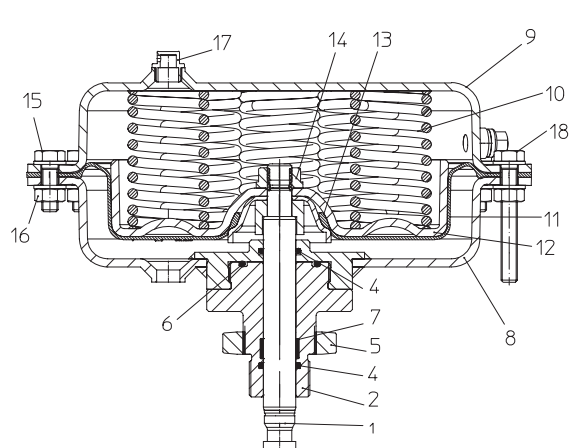

Pneumatic actuator ARI-FA
Spring closes

Pneumatic actuator ARI-FA
Spring opens on air failure

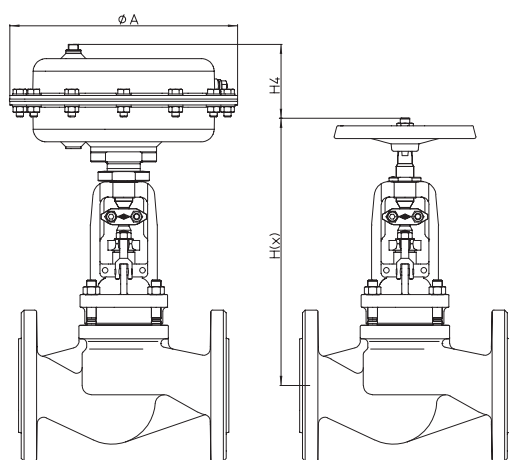

Important:

The pneumatic actuator ARI-FA can be combined with all ARI-FABA-Supra versions with two-piece stem!

Max. medium temperatur in the valve 482°F / 250°C !

Not applicable for design with balancing plugs !

Parts

Pos.	Description	Material
1	Stem	SA276Gr.420
2	Head	SA276Gr.420
4	O-ring *	NBR
5	Lock nut	SA276Gr.420
6	O-ring *	NBR
7	Guiding band *	PTFE -+25%C
8	Lower diaphragm casing	AISI1008 (powder coated)
9	Upper diaphragm casing	AISI1008 (powder coated)
10	Spring *	AISI9254
11	Rolling diaphragm *	NBR + webbing
12	Diaphragm plate	AISI1008 (Fe/Zn12C)
13	Diaphragm flange	AISI1213 (Fe/Zn12C)
14	Collar nut *	St
15	Hexagon bolt	St (galvanised)
16	Hexagon nut	St (galvanised)
17	Vent plug *	Polyäthylen

* Spare part

Type of actuator		FA160	FA250	FA400	FA800
Ø A	(inch)	8,3	9,9	11,8	15,9
H(x)	(inch)	refer to page 4 - 6			
max. H4	(inch)	3,5	4,2	4,7	6,5
max. pressure	(psi)	87	87	87	87
Weight (Actuator)	(lbs)	14,3	13,8	37,5	110
Type of actuator		FA160	FA250	FA400	FA800
Ø A	(mm)	210	250	300	405
H(x)	(mm)	refer to page 4 - 6			
max. H4	(mm)	90	105	120	165
max. pressure	(bar)	6	6	6	6
Weight (Actuator)	(kg)	6,5	9	17	50

max. permissible closing pressures on flow-to-open P2 = 0 (Observe regulations, refer to page 12.)

Spring closes										
NPS		1/2"	3/4"	1"	1 1/2"	2"	2 1/2"	3"	4"	6"
Travel (inch)		0,25	0,25	0,3	0,5	0,5	0,65	0,8	1	1,6
Actuator FA160	Air supply pressure min. (psi)	58	580	580	387					
Actuator FA250		66			297	162	24			
Actuator FA400		66			480	450	215	94	21	
Actuator FA800		73							252	63
Req. air supply press. for pneumatic actuators FA:		max. permissible		6 bar						
DN		15	20	25	40	50	65	80	100	150
Travel (mm)		6	6	8	13	13	16	20	25	40
Actuator FA160	Air supply pressure min. (bar)	4	40	40	26,7					
Actuator FA250		4,5			20,5	11,1	1,6			
Actuator FA400		4,5			40	31	14,8	6,5	1,4	
Actuator FA800		5							17,4	4,3
Req. air supply press. for pneumatic actuators FA:		max. permissible		6 bar						

max. permissible closing pressures on flow-to-open P2 = 0 (Observe regulations, refer to page 12.)

Spring opens on air failure											
NPS		1/2"	3/4"	1"	1 1/2"	2"	2 1/2"	3"	4"	6"	
Travel (inch)		0,25	0,25	0,3	0,5	0,5	0,65	0,8	1	1,6	
Actuator FA160	Air supply pressure min. (psi)	44	580	580	305						
		58	580	580	580						
		73	580	580	580						
		87	580	580	580						
Actuator FA250		44				200	99				
		58				435	251	90			
		73				580	403	181			
		87				580	555	271			
Actuator FA400		44						139	56		
		58						284	152	68	
		73						429	248	130	
		87						573	345	192	
Actuator FA800		44								150	26
		58								274	81
		73								398	137
		87								522	192
Req. air supply press. for pneumatic actuators FA:		max. permissible		87 psi							
DN		15	20	25	40	50	65	80	100	150	
Travel (mm)		6	6	8	13	13	16	20	25	40	
Actuator FA160	Air supply pressure min. (bar)	3	40	40	21,1						
		4	40	40	40						
		5	40	40	40						
		6	40	40	40						
Actuator FA250		3				13,8	6,9				
		4				30	17,3	6,2			
		5				40	27,8	12,5			
		6				40	38,2	18,7			
Actuator FA400		3						9,6	3,9		
		4						19,6	10,5	4,7	
		5						29,6	17,1	9	
		6						39,5	23,8	13,2	
Actuator FA800		3								10,4	1,8
		4								18,9	5,6
		5								27,5	9,4
		6								36	13,2
Req. air supply press. for pneumatic actuators FA:		max. permissible		6 bar							

Standard-flange dimensions

Flanges acc. to ANSI B16.5

NPS		(inch)	1/2"	3/4"	1"	1 1/2"	2"	2 1/2"	3"	4"	6"	8"	10"
ANSI150	ØD1	(inch)	3,5	3,9	4,25	5	6	7	7,52	9	11	13,5	16
ANSI150	ØK1	(inch)	2,36	2,76	3,1	3,86	4,76	5,51	5,98	7,52	9,49	11,73	14,25
ANSI150	n x Ød1	(n x inch)	4 x 0,63	4 x 0,63	4 x 0,63	4 x 0,63	4 x 0,75	4 x 0,75	4 x 0,75	8 x 0,75	8 x 0,87	8 x 0,87	12 x 0,98
ANSI300	ØD2	(inch)	3,74	4,61	4,88	6,1	6,5	7,52	8,27	10	12,52	15	17,52
ANSI300	ØK2	(inch)	2,62	3,25	3,5	4,49	5	5,87	6,61	7,87	10,63	12,99	15,24
ANSI300	n x Ød2	(n x inch)	4 x 0,63	4 x 0,75	4 x 0,75	4 x 0,87	8 x 0,75	8 x 0,87	8 x 0,87	8 x 0,87	12 x 0,87	12 x 0,98	16 x 1,14
DN		(mm)	15	20	25	40	50	65	80	100	150	200	250
ANSI150	ØD1	(mm)	89	99	108	127	153	178	191	229	279	343	406
ANSI150	ØK1	(mm)	60	70	79	98	121	140	152	191	241	298	362
ANSI150	n x Ød1	(n x mm)	4 x 16	4 x 16	4 x 16	4 x 16	4 x 19	4 x 19	4 x 19	8 x 19	8 x 22	8 x 22	12 x 25
ANSI300	ØD2	(mm)	95	117	124	155	165	191	210	254	318	381	445
ANSI300	ØK2	(mm)	66,5	82,5	89	114	127	149	168	200	270	330	387
ANSI300	n x Ød2	(n x mm)	4 x 16	14 x 9	4 x 19	4 x 22	8 x 19	8 x 22	8 x 22	8 x 22	12 x 22	12 x 25	16 x 29

Screwed socket dimensions

NPS		(inch)	1/2"	3/4"	1"	1 1/4"	1 1/2"	2"
ANSI300	lg	(inch)	0,59	0,64	0,75	0,84	0,84	1,01
ANSI300	G (BSP)	(inch)	1/2	3/4	1	1 1/4	1 1/2	2
ANSI300	G (NPT)	(inch)						
DN		(mm)	15	20	25	32	40	50
ANSI300	lg	(mm)	15	16,3	19,1	21,4	21,4	25,7
ANSI300	G (BSP)	(mm)	1/2	3/4	1	1 1/4	1 1/2	2
ANSI300	G (NPT)	(mm)						

Socket weld ends dimensions

NPS		(inch)	1/2"	3/4"	1"	1 1/4"	1 1/2"	2"
ANSI300	l	(inch)	0,39	0,51	0,51	0,51	0,51	0,63
ANSI300	Ød	(inch)	0,85	1,07	1,33	1,67	1,92	2,41
DN		(mm)	15	20	25	32	40	50
ANSI300	l	(mm)	10	13	13	13	13	16
ANSI300	Ød	(mm)	21,7	27,1	33,8	42,5	48,7	61,1

Pressure-temperature-ratings acc. to ANSI

Material			-20°F to 100°F	200°F	300°F	400°F	500°F	600°F	650°F	700°F	750°F	800°F
SA216WCB / SA105	ANSI150	(psi)	285	260	230	200	170	140	125	110	95	80
SA216WCB / SA105	ANSI300	(psi)	740	675	655	635	600	570	550	530	505	410
Material			-29°C to 38°C	93°C	149°C	204°C	260°C	315°C	343°C	371°C	399°C	427°C
SA216WCB / SA105	ANSI150	(bar)	19,6	17,9	15,8	13,8	11,7	9,6	8,69	7,6	6,6	5,5
SA216WCB / SA105	ANSI300	(bar)	51,1	46,6	45,2	43,8	41,4	39,3	37,9	36,6	34,8	28,3

Intermediate values for max. permissible operational pressures can be determined by linear interpolation of the given temperature / pressure chart.

Please indicate when ordering

- Figure-No.
- Nominal pressure
- Nominal diameter
- Special design / accessories

Example:

Figure 32.041; Class 150; Nominal diameter 4".

Dimensions in inch	1 inch Δ 25,4 mm
Dimensions in mm	
Weights in lbs	1 lbs Δ 0,45 kg
Weights in kg	
Pressures in psig	14,5 psi Δ 1 bar
Pressures in barg	
1 bar Δ 10 ⁵ Pa Δ 0,1 MPa	
Cv in us-gallons/min	0,86 Cv Δ 1 Kvs
Kvs in m ³ /h	



Technology for the Future.
GERMAN QUALITY VALVES

ARI-Armaturen Albert Richter GmbH & Co. KG, D-33756 Schloß Holte-Stukenbrock,
Tel. +49 52 07 / 994-0, Telefax +49 52 07 / 994-158 or 159 Internet: <http://www.ari-armaturen.com> E-mail: info.vertrieb@ari-armaturen.com